

OSU78xxA

Descriptions

The OSU78xxA series are three terminal positive voltage regulators designed for a wide variety of applications including local, on-card regulation.

The OSU78xxA are complete with internal current limiting, thermal shutdown protection, and safe-area compensation which make them virtually immune from output overload. If adequate heat sinking is provided, these regulators can deliver output currents up to 1A. The OSU78xxA are available in TO-252-2L, TO-220-3L, TO-220F-3L packages.

Features

- Output Current up to 1A
- Fixed Output Voltages of 5V, 6V, 8V, 9V, 12V, 15V and 18V
- Output Voltage Accuracy of $\pm 4\%$ over the Full Temperature Range
- Internal Short Circuit Current Limiting
- Internal Thermal Overload Protection
- Output Transistor Safe-area Protection
- Low Load Regulation
- Stable Performance in High Temperature TO-220-3L
- Lead-Free Finish; RoHS Compliant
- Lead-Free Packages: TO-252-2L,
- Totally Lead-Free; RoHS Compliant
- Lead-Free Finish; RoHS Compliant
- Totally Lead-Free & Fully RoHS Compliant

Applications

- High Efficiency Linear Regulator
- Post Regulation for Switching Supply
- Microprocessor Power Supply
- Mother Board

Pin Assignments

Top View

TO-252-2L

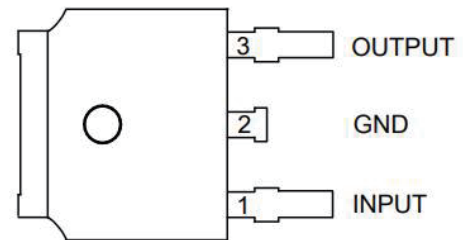

TO-220-3L

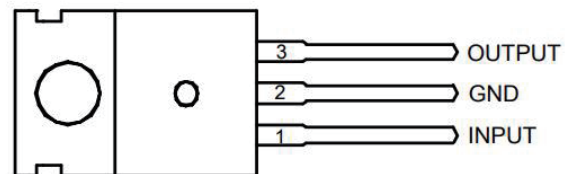

TO-220F-3L

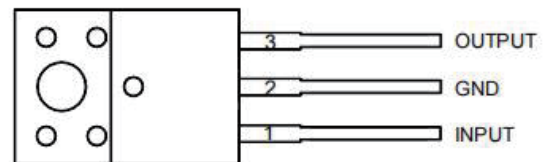

Typical Applications Circuit

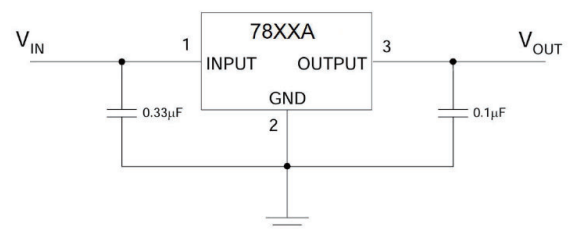

Pin Descriptions

Pin Number	Pin Name	Function
1	INPUT	Voltage Input
2	GND	Ground
3	OUTPUT	Voltage Output

Functional Block Diagram

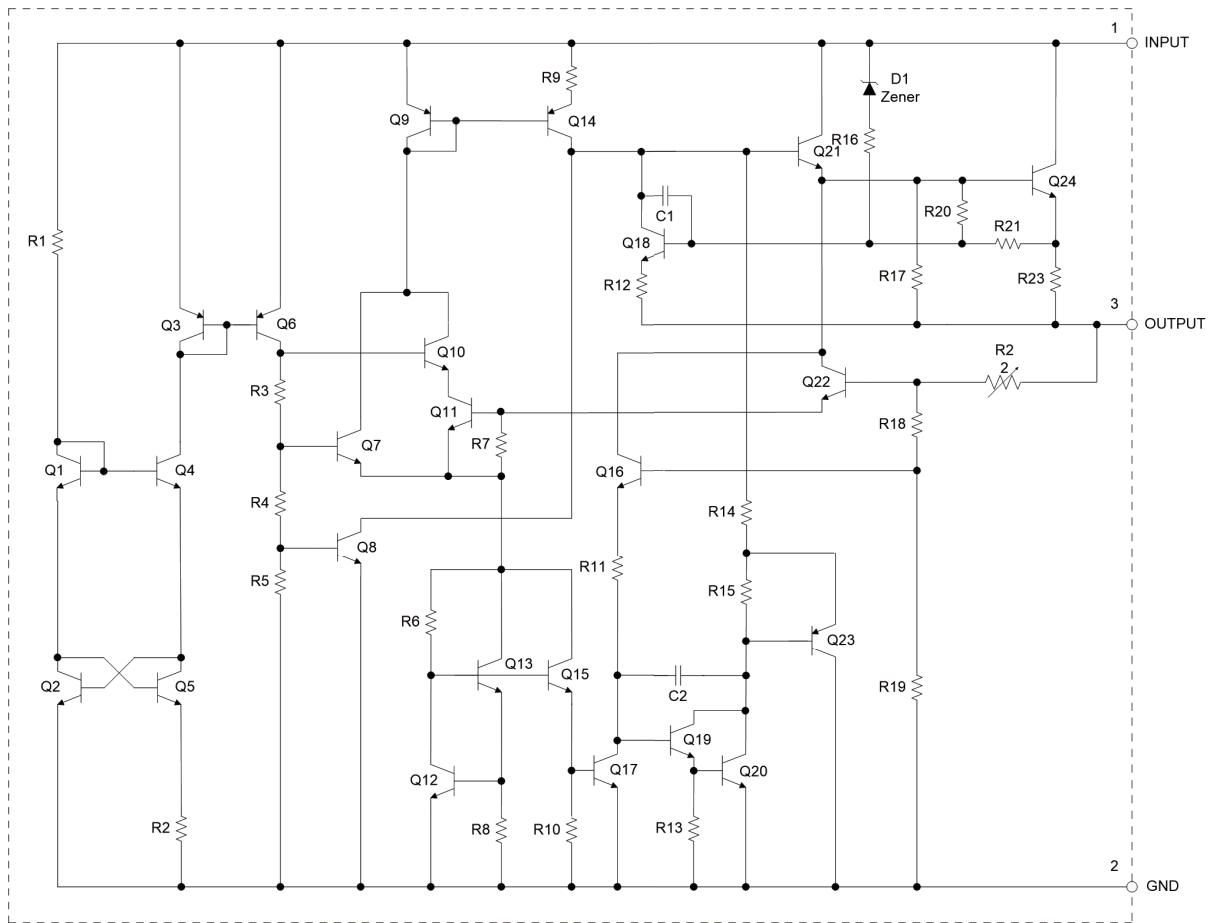

Absolute Maximum Ratings

Symbol	Parameter	Rating		Unit
V _{IN}	Input Voltage	36		V
T _{LEAD}	Lead Temperature (Soldering, 10sec)	+260		°C
P _D	Power Dissipation	Internally Limited		W
T _J	Operating Junction Temperature	+150		°C
T _{STG}	Storage Temperature Range	-65 to +150		°C
θ _{JA}	Thermal Resistance	TO-220-3L	60	°C/W
		TO-252-2L	100	
ESD	ESD (Human Body Model)	6000		V
ESD	ESD (Machine Model)	500		V

Note 1: Stresses greater than those listed under “Absolute Maximum Ratings” may cause permanent damage to the device. These are stress ratings only, and functional operation of the device at these or any other conditions beyond those indicated under “Recommended Operating Conditions” is not implied. Exposure to “Absolute Maximum Ratings” for extended periods may affect device reliability.

Recommended Operating Conditions

Symbol	Parameter	Min	Max	Unit	
V _{IN}	Input Voltage	OSU7805A	–	25	V
		OSU7806A	–	26	
		OSU7808A	–	28	
		OSU7809A	–	29	
		OSU7812A	–	32	
		OSU7815A	–	32	
		OSU7818A	–	32	
T _J	Operating Junction Temperature Range	-40	+125	°C	

Electrical Characteristics

OSU7805A (@ $V_{IN} = 10V$, $I_{OUT} = 1A$, $T_J = -40$ to $+125^\circ C$, unless otherwise specified.)

Symbol	Parameter	Conditions	Min	Typ	Max	Unit
V_{OUT}	Output Voltage	$T_J = +25^\circ C$	4.9	5	5.1	V
		$I_{OUT} = 5mA$ to $1A$, $V_{IN} = 7.5V$ to $20V$, $P_D \leq 15W$	4.8	–	5.2	
V_{RLINE}	Line Regulation	$V_{IN} = 7.5V$ to $20V$, $I_{OUT} = 500mA$, $T_J = +25^\circ C$	–	25	50	mV
V_{RLOAD}	Load Regulation	$V_{IN} = 10V$, $I_{OUT} = 5mA$ to $1A$, $T_J = +25^\circ C$	–	20	50	mV
I_Q	Quiescent Current	$V_{IN} = 10V$, $I_{OUT} = 0$	–	3.2	6	mA
ΔI_Q	Quiescent Current Change	$V_{IN} = 8V$ to $25V$, $I_{OUT} = 500mA$, $T_J = +25^\circ C$	–	0.3	0.8	mA
		$I_{OUT} = 5mA$ to $1A$, $T_J = +25^\circ C$	–	0.08	0.5	
PSRR	Ripple Rejection	$V_{IN} = 8V$ to $18V$, $f = 120Hz$, $I_{OUT} = 500mA$	–	70	–	dB
V_{DROP}	Dropout Voltage	$\Delta V_{OUT} = 1\%$, $I_{OUT} = 1A$, $T_J = +25^\circ C$	–	2	–	V
N_o	Output Noise Voltage	$f = 10Hz$ to $100kHz$, $T_A = +25^\circ C$	–	10	–	$\mu V/V_o$
R_o	Output Resistance	$f = 1kHz$	–	10	–	m Ω
I_{SC}	Short Circuit Current	$V_{IN} = 35V$, $T_A = +25^\circ C$	–	0.05	–	A
I_{PK}	Peak Output Current	$V_{IN} = 10V$, $T_J = +25^\circ C$	–	2.2	–	A
$\Delta V_{OUT}/\Delta T$	Output Voltage Temperature Coefficient	–	–	0.4	–	mV/ $^\circ C$
$(\Delta V_{OUT}/V_{OUT})/\Delta T$		–	–	80	–	ppm/ $^\circ C$
θ_{JC}	Thermal Resistance	TO-220-3L	–	9	–	$^\circ C/W$
		TO-252-2L	–	16	–	
		TO-220F-3L	–	9	–	

OSU7806A (@ $V_{IN} = 11V$, $I_{OUT} = 1A$, $T_J = -40$ to $+125^\circ C$, unless otherwise specified.)

Symbol	Parameter	Conditions	Min	Typ	Max	Unit
V_{OUT}	Output Voltage	$T_J = +25^\circ C$	5.88	6	6.12	V
		$I_{OUT} = 5mA$ to $1A$, $V_{IN} = 8.6V$ to $21V$, $P_D \leq 15W$	5.76	–	6.24	
V_{RLINE}	Line Regulation	$V_{IN} = 8.6V$ to $21V$, $I_{OUT} = 500mA$, $T_J = +25^\circ C$	–	25	60	mV
V_{RLOAD}	Load Regulation	$V_{IN} = 11V$, $I_{OUT} = 5mA$ to $1A$, $T_J = +25^\circ C$	–	20	60	mV
I_Q	Quiescent Current	$V_{IN} = 11V$, $I_{OUT} = 0$	–	3.2	6	mA
ΔI_Q	Quiescent Current Change	$V_{IN} = 8.6V$ to $21V$, $I_{OUT} = 500mA$, $T_J = +25^\circ C$	–	0.3	0.8	mA
		$I_{OUT} = 5mA$ to $1A$, $T_J = +25^\circ C$	–	0.08	0.5	
PSRR	Ripple Rejection	$V_{IN} = 9.5V$ to $19.5V$, $f = 120Hz$, $I_{OUT} = 500mA$	–	65	–	dB
V_{DROP}	Dropout Voltage	$\Delta V_{OUT} = 1\%$, $I_{OUT} = 1A$, $T_J = +25^\circ C$	–	2	–	V
N_O	Output Noise Voltage	$f = 10Hz$ to $100kHz$, $T_A = 25^\circ C$	–	10	–	$\mu V/V_O$
R_O	Output Resistance	$f = 1kHz$	–	10	–	m Ω
I_{SC}	Short Circuit Current	$V_{IN} = 35V$, $T_A = +25^\circ C$	–	0.2	–	A
I_{PK}	Peak Output Current	$V_{IN} = 11V$, $T_J = +25^\circ C$	–	2.2	–	A
$\Delta V_{OUT}/\Delta T$	Output Voltage Temperature	–	–	0.5	–	mV/ $^\circ C$
$(\Delta V_{OUT}/V_{OUT})/\Delta T$	Coefficient	–	–	80	–	ppm/ $^\circ C$
θ_{JC}	Thermal Resistance	TO-220-3L	–	9	–	$^\circ C/W$
		TO-252-2L	–	16	–	
		TO-220F-3L	–	9	–	

OSU7808A (@ $V_{IN} = 14V$, $I_{OUT} = 1A$, $T_J = -40$ to $+125^\circ C$, unless otherwise specified.)

Symbol	Parameter	Conditions	Min	Typ	Max	Unit
V_{OUT}	Output Voltage	$T_J = +25^\circ C$	7.84	8	8.16	V
		$I_{OUT} = 5mA$ to $1A$, $V_{IN} = 10.6V$ to $23V$, $P_D \leq 15W$	7.7	–	8.3	
V_{RLINE}	Line Regulation	$V_{IN} = 10.6V$ to $23V$, $I_{OUT} = 500mA$, $T_J = +25^\circ C$	–	25	75	mV
V_{RLOAD}	Load Regulation	$V_{IN} = 14V$, $I_{OUT} = 5mA$ to $1A$, $T_J = +25^\circ C$	–	25	75	mV
I_Q	Quiescent Current	$V_{IN} = 14V$, $I_{OUT} = 0$	–	3.2	6	mA
ΔI_Q	Quiescent Current Change	$V_{IN} = 10.6V$ to $23V$, $I_{OUT} = 500mA$, $T_J = +25^\circ C$	–	0.3	0.8	mA
		$I_{OUT} = 5mA$ to $1A$, $T_J = +25^\circ C$	–	0.08	0.5	
PSRR	Ripple Rejection	$V_{IN} = 11.5V$ to $21.5V$, $f = 120Hz$, $I_{OUT} = 500mA$	–	62	–	dB
V_{DROP}	Dropout Voltage	$\Delta V_{OUT} = 1\%$, $I_{OUT} = 1A$, $T_J = +25^\circ C$	–	2	–	V
N_O	Output Noise Voltage	$f = 10Hz$ to $100kHz$, $T_A = +25^\circ C$	–	10	–	$\mu V/V_O$
R_O	Output Resistance	$f = 1kHz$	–	10	–	$m\Omega$
I_{SC}	Short Circuit Current	$V_{IN} = 35V$, $T_A = +25^\circ C$	–	0.2	–	A
I_{PK}	Peak Output Current	$V_{IN} = 14V$, $T_J = +25^\circ C$	–	2.2	–	A
$\Delta V_{OUT}/\Delta T$	Output Voltage Temperature	–	–	0.64	–	$mV/^\circ C$
$(\Delta V_{OUT}/V_{OUT})/\Delta T$	Coefficient	–	–	80	–	ppm/ $^\circ C$
θ_{JC}	Thermal Resistance	TO-220-3L	–	9	–	$^\circ C/W$
		TO-252-2L	–	16	–	
		TO-220F-3L	–	9	–	

OSU7809A (@ $V_{IN} = 15V$, $I_{OUT} = 1A$, $T_J = -40$ to $+125^\circ C$, unless otherwise specified.)

Symbol	Parameter	Conditions	Min	Typ	Max	Unit
V_{OUT}	Output Voltage	$T_J = +25^\circ C$	8.82	9	9.18	V
		$I_{OUT} = 5mA$ to $1A$, $V_{IN} = 11.5V$ to $23V$, $P_D \leq 15W$	8.65	–	9.35	
V_{RLINE}	Line Regulation	$V_{IN} = 11.5V$ to $23V$, $I_{OUT} = 500mA$, $T_J = +25^\circ C$	–	25	90	mV
V_{RLOAD}	Load Regulation	$V_{IN} = 14V$, $I_{OUT} = 5mA$ to $1A$, $T_J = +25^\circ C$	–	25	100	mV
I_Q	Quiescent Current	$V_{IN} = 15V$, $I_{OUT} = 0$	–	3.2	6	mA
ΔI_Q	Quiescent Current Change	$V_{IN} = 11.5V$ to $23V$, $I_{OUT} = 500mA$, $T_J = +25^\circ C$	–	0.3	0.8	mA
		$I_{OUT} = 5mA$ to $1A$, $T_J = +25^\circ C$	–	0.08	0.5	
PSRR	Ripple Rejection	$V_{IN} = 11.5V$ to $21.5V$, $f = 120Hz$, $I_{OUT} = 500mA$	–	61	–	dB
V_{DROP}	Dropout Voltage	$\Delta V_{OUT} = 1\%$, $I_{OUT} = 1A$, $T_J = +25^\circ C$	–	2	–	V
N_O	Output Noise Voltage	$f = 10Hz$ to $100kHz$, $T_A = +25^\circ C$	–	10	–	$\mu V/V_O$
R_O	Output Resistance	$f = 1kHz$	–	10	–	m Ω
I_{SC}	Short Circuit Current	$V_{IN} = 35V$, $T_A = +25^\circ C$	–	0.2	–	A
I_{PK}	Peak Output Current	$V_{IN} = 15V$, $T_J = +25^\circ C$	–	2.2	–	A
$\Delta V_{OUT}/\Delta T$	Output Voltage Temperature	–	–	0.72	–	mV/ $^\circ C$
$(\Delta V_{OUT}/V_{OUT})/\Delta T$	Coefficient	–	–	80	–	ppm/ $^\circ C$
θ_{JC}	Thermal Resistance	TO-220-3L	–	9	–	$^\circ C/W$
		TO-252-2L	–	16	–	
		TO-220F-3L	–	9	–	

OSU7812A (@ $V_{IN} = 19V$, $I_{OUT} = 1A$, $T_J = -40$ to $+125^\circ C$, unless otherwise specified.)

Symbol	Parameter	Conditions	Min	Typ	Max	Unit
V_{OUT}	Output Voltage	$T_J = +25^\circ C$	11.75	12	12.25	V
		$I_{OUT} = 5mA$ to $1A$, $V_{IN} = 14.8V$ to $27V$, $P_D \leq 15W$	11.5	–	12.5	
V_{RLINE}	Line Regulation	$V_{IN} = 14.8V$ to $27V$, $I_{OUT} = 500mA$, $T_J = +25^\circ C$	–	25	120	mV
V_{RLOAD}	Load Regulation	$V_{IN} = 19V$, $I_{OUT} = 5mA$ to $1A$, $T_J = +25^\circ C$	–	40	120	mV
I_Q	Quiescent Current	$V_{IN} = 19V$, $I_{OUT} = 0$	–	3.4	6	mA
ΔI_Q	Quiescent Current Change	$V_{IN} = 14.8V$ to $30V$, $I_{OUT} = 500mA$, $T_J = +25^\circ C$	–	0.3	0.8	mA
		$I_{OUT} = 5mA$ to $1A$, $T_J = +25^\circ C$	–	0.08	0.5	
PSRR	Ripple Rejection	$V_{IN} = 15V$ to $25V$, $f = 120Hz$, $I_{OUT} = 500mA$	–	60	–	dB
V_{DROP}	Dropout Voltage	$\Delta V_{OUT} = 1\%$, $I_{OUT} = 1A$, $T_J = +25^\circ C$	–	2	–	V
N_O	Output Noise Voltage	$f = 10Hz$ to $100kHz$, $T_A = +25^\circ C$	–	10	–	$\mu V/V_O$
R_O	Output Resistance	$f = 1kHz$	–	11	–	m Ω
I_{SC}	Short Circuit Current	$V_{IN} = 35V$, $T_A = +25^\circ C$	–	0.2	–	A
I_{PK}	Peak Output Current	$V_{IN} = 18V$, $T_J = +25^\circ C$	–	2.2	–	A
$\Delta V_{OUT}/\Delta T$	Output Voltage Temperature	–	–	0.96	–	mV/ $^\circ C$
$(\Delta V_{OUT}/V_{OUT})/\Delta T$	Coefficient	–	–	80	–	ppm/ $^\circ C$
θ_{JC}	Thermal Resistance	TO-220-3L	–	9	–	$^\circ C/W$
		TO-252-2L	–	16	–	
		TO-220F-3L	–	9	–	

OSU7815A (@ $V_{IN} = 23V$, $I_{OUT} = 1A$, $T_J = -40$ to $+125^\circ C$, unless otherwise specified.)

Symbol	Parameter	Conditions	Min	Typ	Max	Unit
V_{OUT}	Output Voltage	$T_J = +25^\circ C$	14.7	15	15.3	V
		$I_{OUT} = 5mA$ to $1A$, $V_{IN} = 17.9V$ to $30V$, $P_D \leq 15W$	14.4	–	15.6	
V_{RLINE}	Line Regulation	$V_{IN} = 17.9V$ to $30V$, $I_{OUT} = 500mA$, $T_J = +25^\circ C$	–	35	150	mV
V_{RLOAD}	Load Regulation	$V_{IN} = 23V$, $I_{OUT} = 5mA$ to $1A$, $T_J = +25^\circ C$	–	70	150	mV
I_Q	Quiescent Current	$V_{IN} = 23V$, $I_{OUT} = 0$	–	3.4	6	mA
ΔI_Q	Quiescent Current Change	$V_{IN} = 17.9V$ to $30V$, $I_{OUT} = 500mA$, $T_J = +25^\circ C$	–	0.3	0.8	mA
		$I_{OUT} = 5mA$ to $1A$, $T_J = +25^\circ C$	–	0.08	0.5	
PSRR	Ripple Rejection	$V_{IN} = 18.5V$ to $28.5V$, $f = 120Hz$, $I_{OUT} = 500mA$	–	58	–	dB
V_{DROP}	Dropout Voltage	$\Delta V_{OUT} = 1\%$, $I_{OUT} = 1A$, $T_J = +25^\circ C$	–	2	–	V
N_o	Output Noise Voltage	$f = 10Hz$ to $100kHz$, $T_A = +25^\circ C$	–	10	–	$\mu V/V_o$
R_o	Output Resistance	$f = 1kHz$	–	11	–	m Ω
I_{SC}	Short Circuit Current	$V_{IN} = 35V$, $T_A = +25^\circ C$	–	0.2	–	A
I_{PK}	Peak Output Current	$V_{IN} = 21V$, $T_J = +25^\circ C$	–	2.2	–	A
$\Delta V_{OUT}/\Delta T$	Output Voltage Temperature	–	–	1.2	–	mV/ $^\circ C$
$(\Delta V_{OUT}/V_{OUT})/\Delta T$	Coefficient	–	–	80	–	ppm/ $^\circ C$
θ_{JC}	Thermal Resistance	TO-220-3L	–	9	–	$^\circ C/W$
		TO-252-2L	–	16	–	
		TO-220F-3L	–	9	–	

OSU7818A (@ $V_{IN} = 27V$, $I_{OUT} = 1A$, $T_J = -40$ to $+125^{\circ}C$, unless otherwise specified.)

Symbol	Parameter	Conditions	Min	Typ	Max	Unit
V_{OUT}	Output Voltage	$T_J = +25^{\circ}C$	17.64	18	18.36	V
		$I_{OUT} = 5mA$ to $1A$, $V_{IN} = 21V$ to $33V$, $P_D \leq 15W$	17.3	–	18.7	
V_{RLINE}	Line Regulation	$V_{IN} = 21V$ to $33V$, $I_{OUT} = 500mA$, $T_J = +25^{\circ}C$	–	45	180	mV
V_{RLOAD}	Load Regulation	$V_{IN} = 27V$, $I_{OUT} = 5mA$ to $1A$, $T_J = +25^{\circ}C$	–	85	180	mV
I_Q	Quiescent Current	$V_{IN} = 27V$, $I_{OUT} = 0$	–	3.6	6	mA
ΔI_Q	Quiescent Current Change	$V_{IN} = 21V$ to $33V$, $I_{OUT} = 500mA$, $T_J = +25^{\circ}C$	–	0.3	0.8	mA
		$I_{OUT} = 5mA$ to $1A$, $T_J = +25^{\circ}C$	–	0.08	0.5	
PSRR	Ripple Rejection	$V_{IN} = 22V$ to $32V$, $f = 120Hz$, $I_{OUT} = 500mA$	–	57	–	dB
V_{DROP}	Dropout Voltage	$\Delta V_{OUT} = 1\%$, $I_{OUT} = 1A$, $T_J = +25^{\circ}C$	–	2	–	V
N_O	Output Noise Voltage	$f = 10Hz$ to $100kHz$, $T_A = +25^{\circ}C$	–	10	–	$\mu V/V_O$
R_O	Output Resistance	$f = 1kHz$	–	11	–	$m\Omega$
I_{SC}	Short Circuit Current	$V_{IN} = 35V$, $T_A = +25^{\circ}C$	–	0.2	–	A
I_{PK}	Peak Output Current	$V_{IN} = 24V$, $T_J = +25^{\circ}C$	–	2.2	–	A
$\Delta V_{OUT}/\Delta T$	Output Voltage Temperature	–	–	1.44	–	$mV/^{\circ}C$
$(\Delta V_{OUT}/V_{OUT})/\Delta T$	Coefficient	–	–	80	–	$ppm/^{\circ}C$
θ_{JC}	Thermal Resistance	TO-220-3L	–	9	–	$^{\circ}C/W$
		TO-252-2L	–	16	–	
		TO-220F-3L	–	9	–	

Performance Characteristics

Peak Output Current vs. Input/Output Differential Voltage

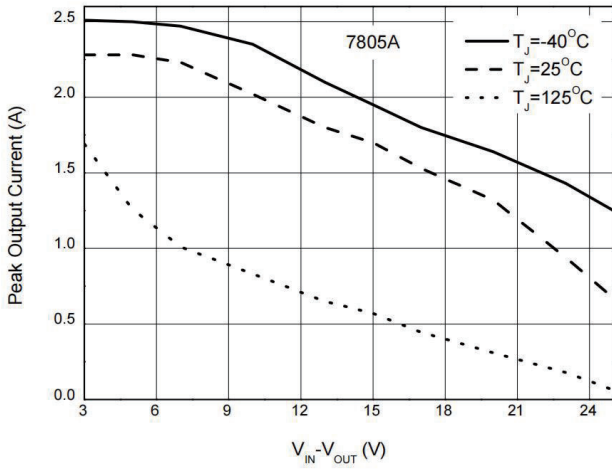

Output Voltage vs. Junction Temperature

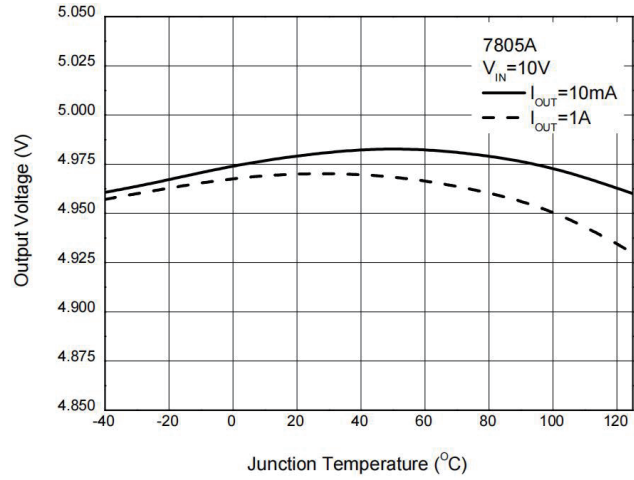

Output Voltage vs. Output Current

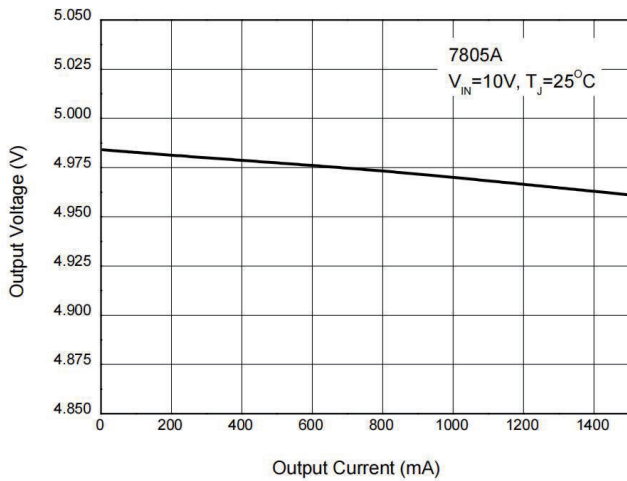

Output Voltage vs. Input Voltage

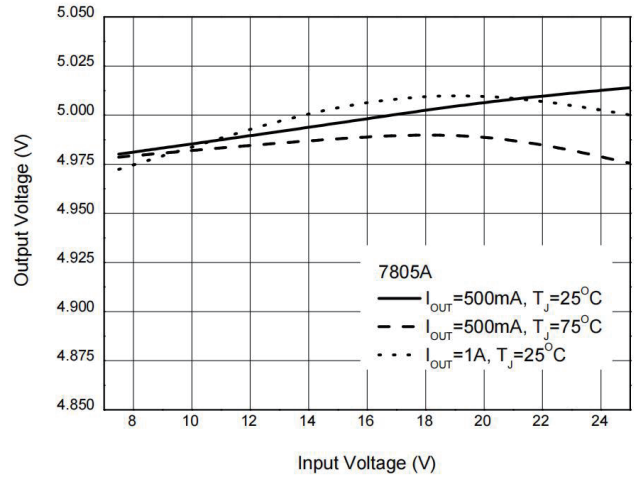

Quiescent Current vs. Junction Temperature

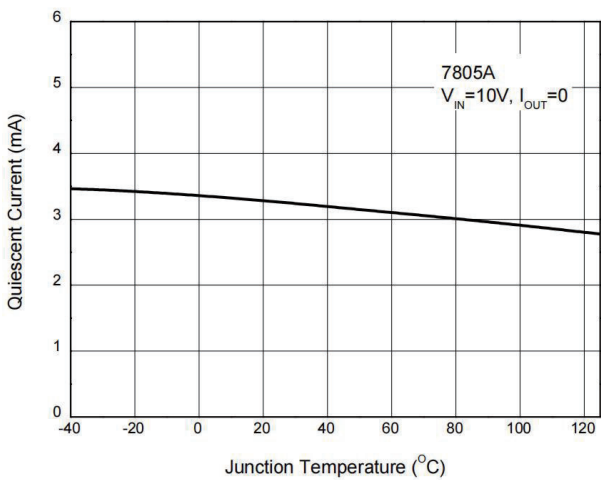

Ripple Rejection vs. Frequency

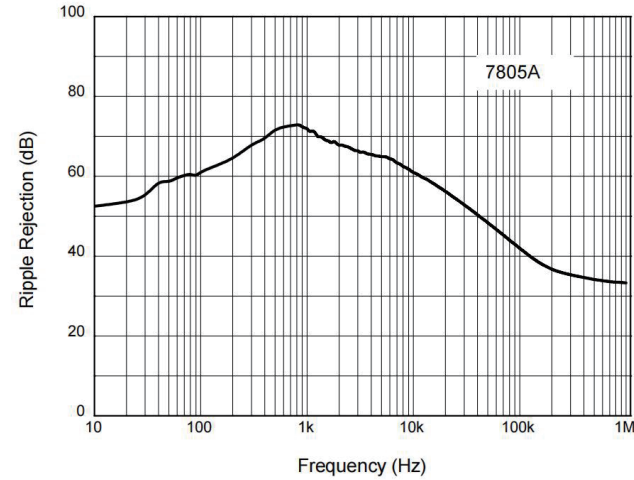

Dropout Voltage vs. Junction Temperature

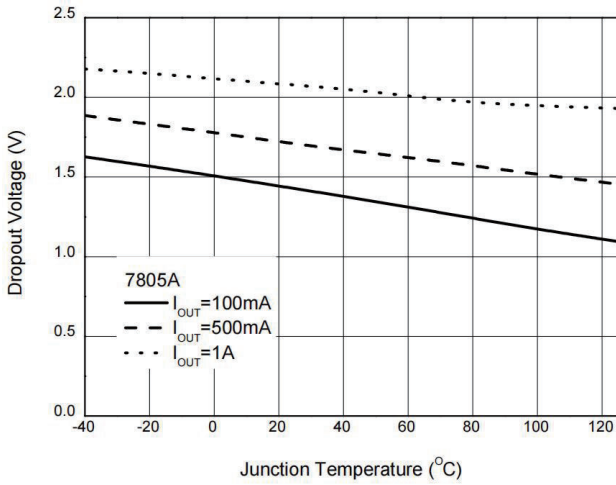

Power Dissipation vs. Junction Temperature

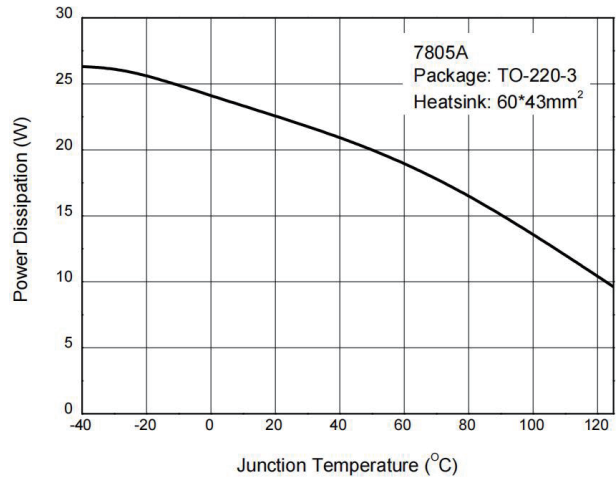

Line Transient

(Conditions: $I_{OUT} = 500mA$, $C_{OUT} = 0.1\mu F$)

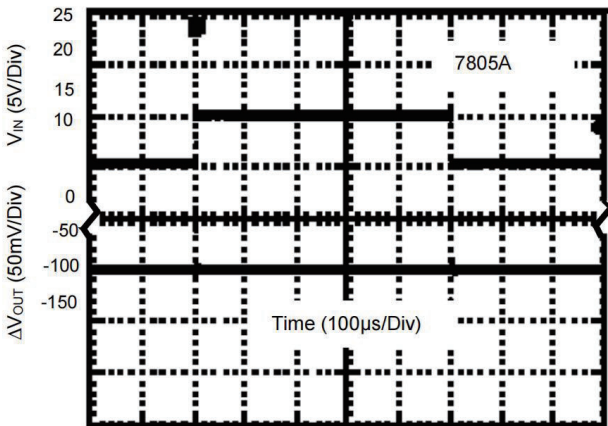

Load Transient

(Conditions: $V_{IN} = 10V$, $C_{IN} = 0.33\mu F$, $C_{OUT} = 0.1\mu F$)

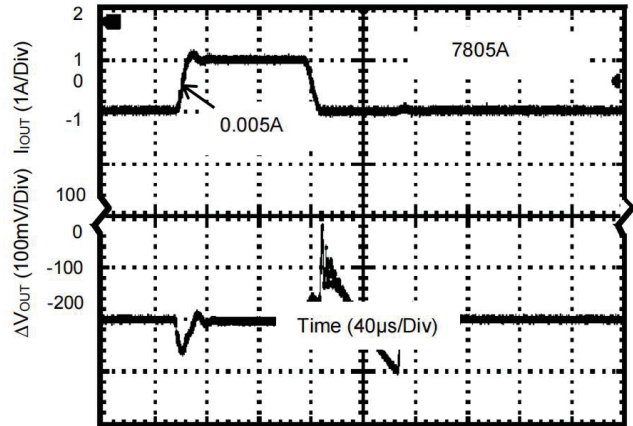

Ordering Information

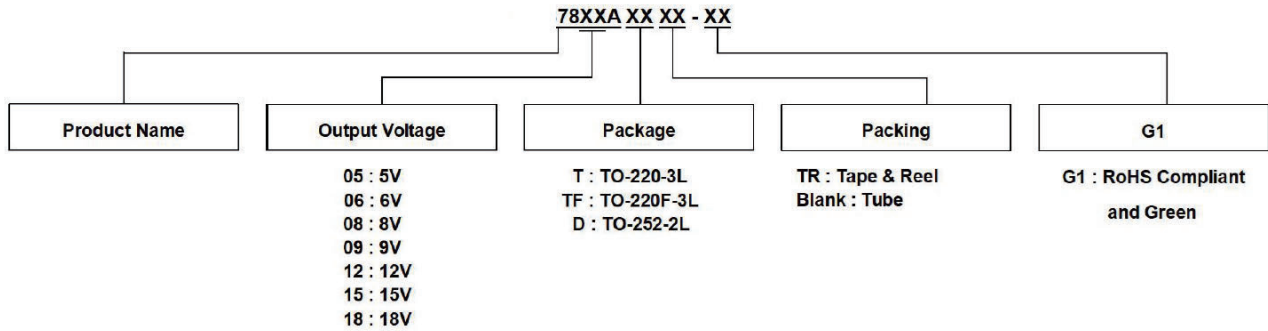

Package	Temperature Range	Part Number	Marking ID	Packing
		Green	Green	
TO-220-3L	-40 to +125°C	OSU7805AT-G1	7805AT-G1	1000/Tube
		OSU7806AT-G1	7806AT-G1	1000/Tube
		OSU7808AT-G1	7808AT-G1	1000/Tube
		OSU7809AT-G1	7809AT-G1	1000/Tube
		OSU7812AT-G1	7812AT-G1	1000/Tube
		OSU7815AT-G1	7815AT-G1	1000/Tube
		OSU7818AT-G1	7818AT-G1	1000/Tube
TO-252-2L	-40 to +125°C	OSU7805ADTR-G1	7805AD-G1	2500/Tape & Reel
		OSU7806ADTR-G1	7806AD-G1	2500/Tape & Reel
		OSU7808ADTR-G1	7808AD-G1	2500/Tape & Reel
		OSU7809ADTR-G1	7809AD-G1	2500/Tape & Reel
		OSU7812ADTR-G1	7812AD-G1	2500/Tape & Reel
		OSU7815ADTR-G1	7815AD-G1	2500/Tape & Reel
		OSU7818ADTR-G1	7818AD-G1	2500/Tape & Reel
TO-220F-3L	-40 to +125°C	OSU7805ATF-G1	7805ATF-G1	1000/Tube
		OSU7806ATF-G1	7806ATF-G1	1000/Tube
		OSU7808ATF-G1	7808ATF-G1	1000/Tube
		OSU7809ATF-G1	7809ATF-G1	1000/Tube
		OSU7812ATF-G1	7812ATF-G1	1000/Tube
		OSU7815ATF-G1	7815ATF-G1	1000/Tube
		OSU7818ATF-G1	7818ATF-G1	1000/Tube

Marking Information

(1)TO-220-3L

(Front View)

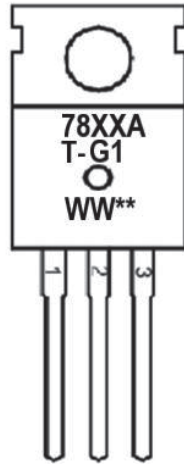

First and Second Lines: Marking ID

(See Ordering Information)

Third Line: Date Code

WW : Work Week of Molding

** : Internal Code

(2)TO-252-2L

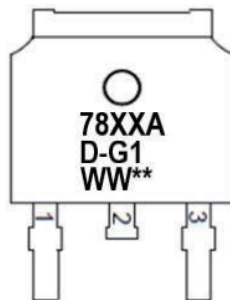

First and Second Lines: Marking ID

(See Ordering Information)

Third Line: Date Code

WW : Work Week of Molding

** : Internal Code

(3)TO-220F-3L

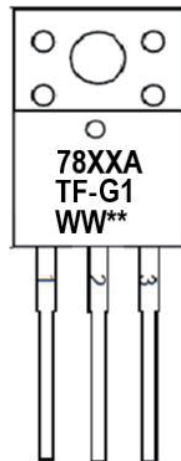

First and Second Lines: Marking ID

(See Ordering Information)

Third Line: Date Code

WW : Work Week of Molding

** : Internal Code

Package Outline Dimensions

(1) Package Type: TO-220-3L

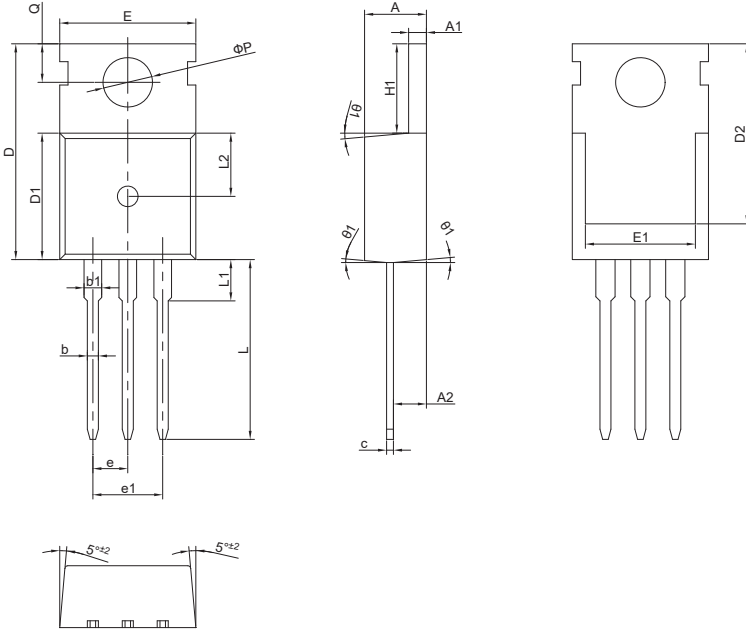

SYMBOL	Dimensions in Millimeters		
	MIN	NOM	MAX
A	4.40	4.50	4.60
A1	1.27	1.30	1.33
A2	2.30	2.40	2.50
b	0.70	-	0.90
b 1	1.30	-	1.45
c	0.45	0.50	0.60
D	15.30	15.70	16.10
D1	9.10	9.20	9.30
D2	12.90	13.10	13.30
E	9.70	9.90	10.20
E1	7.70	7.90	8.10
e	2.45BSC		
e 1	5.08BSC		
H1	6.30	6.50	6.70
L	12.78	13.08	13.38
L1	-	-	3.50
L2	4.06REF		
ΦP	3.55	3.60	3.65
Q	2.73	-	2.87
θ1	3°	5°	7°

(2) TO-252-2L

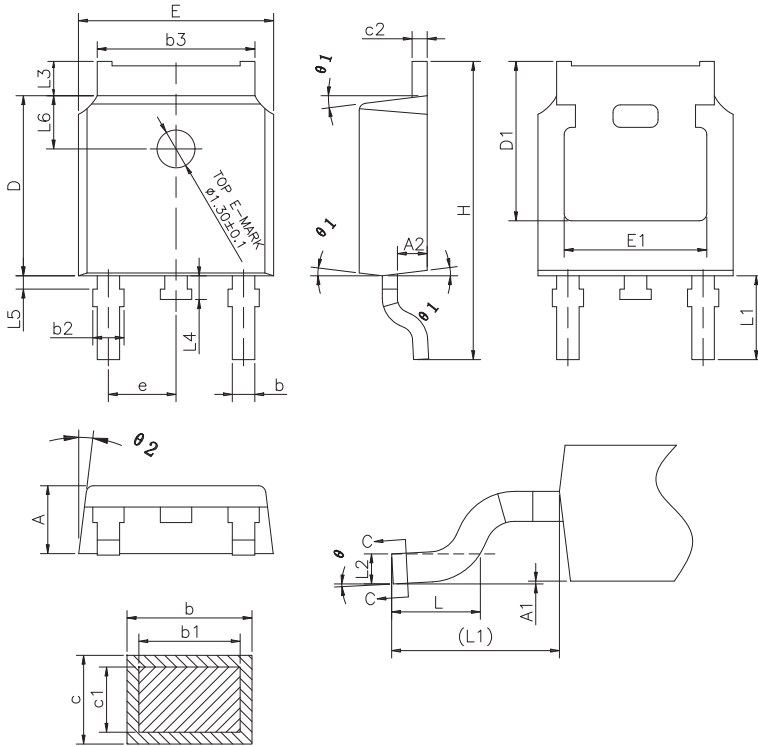

SYMBOL	Dimensions in Millimeters		
	MIN	NOM	MAX
A	2.20	2.30	2.38
A1	0.00	-	0.10
A2	0.90	1.01	1.10
b	0.72	-	0.85
b1	0.71	0.76	0.81
b2	0.72	-	0.90
b3	5.13	5.33	5.46
c	0.47	-	0.60
c1	0.46	0.51	0.56
c2	0.47	-	0.60
D	6.00	6.10	6.20
D1	5.25	-	-
E	6.50	6.60	6.70
E1	4.70	-	-
e	2.186	2.286	2.386
H	9.80	10.10	10.40
L	1.40	1.50	1.70
L1	2.90 REF		
L2	0.508 BSC		
L3	0.90	-	1.25
L4	0.60	0.80	1.00
L5	0.15	-	0.75
L6	1.80 REF		
θ	0°	-	8°
θ1	5°	7°	9°
θ2	5°	7°	9°

(3) TO-220F-3L

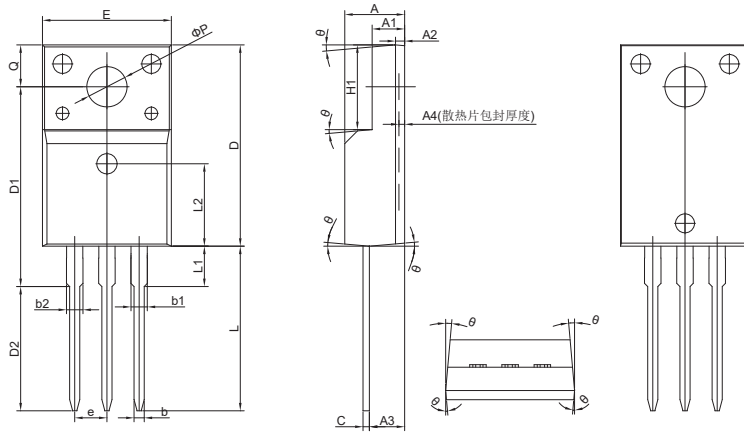

SYMBOL	Dimensions in Millimeters		
	MIN	NOM	MAX
A	4.50	4.72	4.90
A1	2.45	2.56	2.65
A2	0.72REF		
A3	2.68	2.78	2.88
A4	0.45MAX		
b	0.70	-	0.90
b 1	1.18	-	1.38
b 2	-	-	1.38
c	0.45	0.50	0.60
D	15.67	15.87	16.07
D1	15.55	15.75	15.95
D2	9.60	9.80	10.00
E	9.96	10.16	10.36
e	2.54BSC		
H1	6.48	6.68	6.88
L	12.68	12.98	13.28
L1	3.00	-	3.50
L2	6.50REF		
ΦP	3.08	3.18	3.28
Q	3.20	-	3.40
θ	3°	5°	7°

Tape and Reel Information

Reel Dimensions

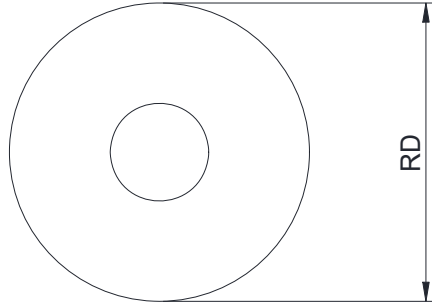

Tape Dimensions

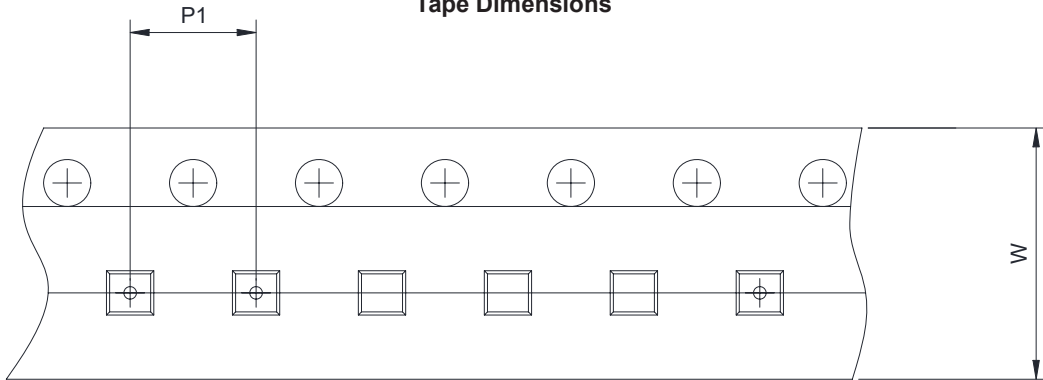

Quadrant Assignments for Pin1 Orientation in Tape

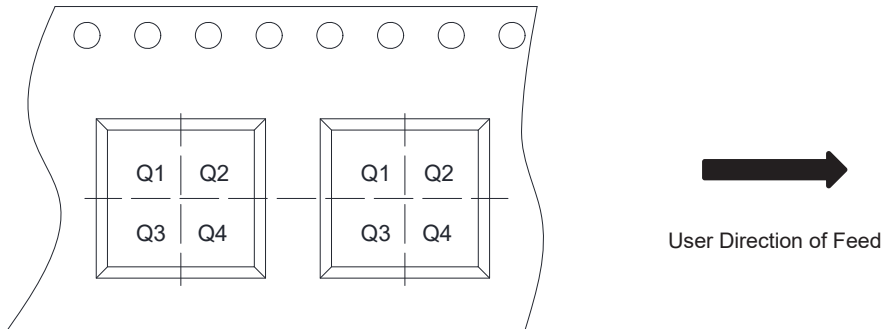

Project		TO-252-2L
RD	Reel Dimension	13inch
W	Overall Width of the Carrier Tape	16mm
P1	Pitch between Successive Cavity Centers	8mm
Pin1	Pin1 Quadrant	Q2

Legal Disclaimer

The information given in this document shall in no event be regarded as a guarantee of conditions or characteristics. With respect to any examples or hints given herein, any typical values stated herein and/or any information regarding the application of the device, Oriental Semiconductor hereby disclaims any and all warranties and liabilities of any kind, including without limitation, warranties of non-infringement of intellectual property rights of any third party.

For further information on technology, delivery terms and conditions and prices, please contact the Oriental Semiconductor sales representatives (www.orientalsemi.com).

© Oriental Semiconductor Co.,Ltd. All Rights Reserved